

MINI JUMBO

VACUUM PACKAGING MACHINE



FEATURES

- Standard with 1 seal bar (front): 280 mm
- Standard double seal (two wires). Optional without extra costs: Cut-off seal
- Seal bars easily removable for cleaning and maintenance purposes
- Pump capacity: 4 m³/h Busch vacuum pump
- Pump maintenance and cleaning program
- Machine cycle: 25-60 sec
- Standard Time control with a 1 program memory
- Deep drawn stainless steel vacuum chamber
- Stainless steel exterior and transparent lid
- Comes with insert plate for a faster cycle and product adjustment

OPTIONS

- High lid
- Sensor control

ACCESSORIES

- Inclined insert plate (for packing liquids)
- Food container adaptor
- Service kit for standard maintenance
- Trolley with shelves

DESCRIPTION

The robust, stainless steel Mini Jumbo vacuum packaging machine is standard equipped with a Busch vacuum pump and Time control with a 1 program memory. This table-top model complies with CE standards.



Henkelman offers standard 3 year warranty

VACUUM PACAGKING MACHINE MINI JUMBO – SPECS

DIMENSIONS

In mm

OUTER DIMENSIONS
Mini Jumbo

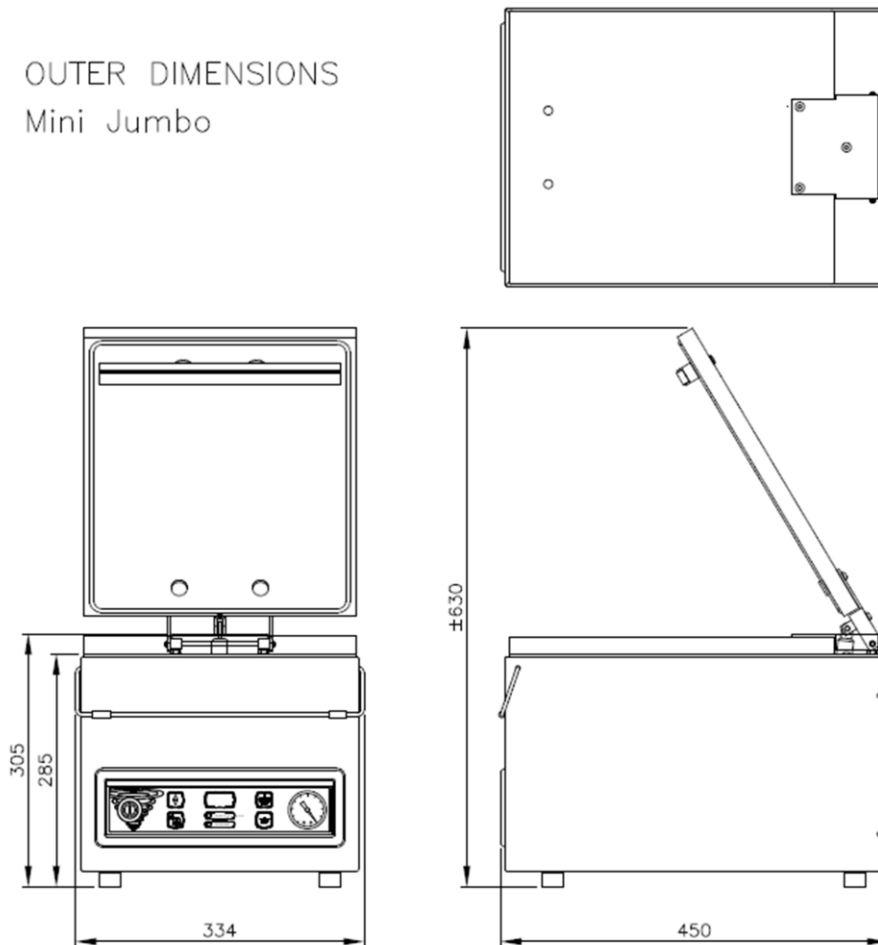

Model	Dimensions (mm)		Voltage*	Pump capacity (m ³ /h)	Power (kW)	Weight (kg)
	Chamber (usable space) L x W x H	Machine L x W x H				
Mini Jumbo	310 x 280 x 85	450 x 334 x 305	230V-1-50	4	0,3	26

* Other voltages available



HENKELMAN BV
Titaniumlaan 10
5221 CK 's-Hertogenbosch
The Netherlands

Sales support
P +31 73 621 36 71
E info@henkelman.com
Service/technical support
P +31 73 621 36 71
E service@henkelman.com